

SEC: SR-MPC:  
TIME: 3 Hrs.

GTRAND TEST-03  
EAPCET MODEL EXAM

EX. DT:  
Max. Marks: 160 M

MATHEMATICS

- If  $f(x) = \frac{2x-3}{3x-2}$  and  $f_n(x) = (f \circ f \circ f \circ \dots \circ f)(x)$  then  $f_{32}(x) =$  \_\_\_\_\_  
1)  $\frac{2x-3}{3x-2}$                       2)  $x$                       3)  $\frac{3x+2}{2x+3}$                       4)  $f_{23}(x)$
- Which of the following functions are odd?  
I)  $f(x) = x \left( \frac{e^x - 1}{e^x + 1} \right)$                       II)  $f(x) = k^x + k^{-x} + \cos x$   
III)  $f(x) = \log(x + \sqrt{x^2 + 1})$   
1) II                      2) I, II                      3) III                      4) I
- $\frac{1}{3.7} + \frac{1}{7.11} + \frac{1}{11.5} + \dots$  upto 50 terms =  
1)  $\frac{50}{203}$                       2)  $\frac{50}{609}$                       3)  $\frac{150}{203}$                       4)  $\frac{25}{609}$
- Let A, B, C, D and E be  $n \times n$  matrices, each with non-zero determinate is  $ABCDE = 1$  then  $C^{-1} =$  \_\_\_\_\_  
1)  $E^{-1}D^{-1}B^{-1}A^{-1}$                       2)  $DEAB$                       3)  $A^{-1}B^{-1}D^{-1}E^{-1}$                       4)  $ABDE$
- If  $3A = \begin{bmatrix} 1 & 2 & 2 \\ 2 & 1 & -2 \\ a & 2 & b \end{bmatrix}$  and  $A^t A = I$ , then  $\frac{a}{b} + \frac{b}{a} =$  \_\_\_\_\_  
1)  $-\frac{5}{2}$                       2)  $\frac{13}{6}$                       3)  $-\frac{13}{6}$                       4)  $\frac{5}{2}$
- If the homogeneous system of linear equations  $x - 2y + 3z = 0$ ,  $2x + 4y - 5z = 0$ ,  $3x + \lambda y + \mu z = 0$ , has non-trivial solutions, then  $8\mu + 11\lambda =$  \_\_\_\_\_  
1) 2                      2) 6                      3) -6                      4) -2
- If  $\begin{vmatrix} a & 1 & 1 \\ 1 & b & 1 \\ 1 & 1 & c \end{vmatrix} > 0$ , then  $abc >$  is  
1) 1                      2) -8                      3) 8                      4) 3
- If the vectors  $a\bar{i} + \bar{j} + \bar{k}$ ,  $\bar{i} + b\bar{j} + \bar{k}$ ,  $\bar{i} + \bar{j} + c\bar{k}$  ( $a \neq b \neq c \neq 1$ ) are coplanar, then  $\frac{1}{1-a} + \frac{1}{1-b} + \frac{1}{1-c} =$   
1) 0                      2) 1                      3) 2                      4) -1
- If M, N are the mid points of the sides PQ, QR and RP of  $\Delta PQR$  respectively, then  $\overline{QM} + \overline{LN} + \overline{ML} + \overline{RN} - \overline{MN} - \overline{QL} =$   
1)  $\overline{PQ} + \overline{QR} + \overline{LM} + \overline{MN}$                       2)  $\overline{LP} + \overline{PM} + \overline{MQ}$   
3)  $\overline{PQ} + \overline{QR} + \overline{RP}$                       4)  $\overline{LM} + \overline{MN} + \overline{RN}$
- The work done by the force  $\vec{F} = 2\vec{i} - 3\vec{j} + 2\vec{k}$  in moving a particle from (3, 4, 5) to (1, 2, 3) is

- 1) 0                      2)  $\frac{3}{2}$                       3) -4                      4) -2

11. If  $|\vec{a}|=1$ ,  $|\vec{b}|=2$  and the angle between  $\vec{a}$  and  $\vec{b}$  is  $120^\circ$ , then  $\{(\vec{a}+3\vec{b})\times(3\vec{a}-\vec{b})\}^2 =$

- 1) 425                      2) 375                      3) 325                      4) 300

12. If  $\vec{a} = 2\vec{i} + 3\vec{j} - 4\vec{k}$ ,  $\vec{b} = \vec{i} + \vec{j} + \vec{k}$  and  $\vec{c} = 4\vec{i} + 2\vec{j} + 3\vec{k}$  then  $|\vec{a} \times (\vec{b} \times \vec{c})|$  is

- 1)  $\sqrt{10}$                       2) 1                      3) 2                      4)  $\sqrt{5}$

13. Let  $\vec{V} = 2\vec{i} + \vec{j} - \vec{k}$  and  $\vec{W} = \vec{i} + 3\vec{k}$ . If  $\vec{U}$  is a unit vector then the maximum value of the scalar triple product  $[\vec{U} \vec{V} \vec{W}]$  is

- 1) -1                      2)  $\sqrt{10} + \sqrt{16}$                       3)  $\sqrt{59}$                       4)  $\sqrt{60}$

14.  $\tan^2 \frac{\pi}{16} + \tan^2 \frac{2\pi}{6} + \tan^2 \frac{3\pi}{16} + \tan^2 \frac{4\pi}{16} + \tan^2 \frac{5\pi}{16} + \tan^2 \frac{6\pi}{16} + \tan^2 \frac{7\pi}{16} =$  \_\_\_\_\_

- 1) 35                      2) 41                      3) 37                      4) 47

15.  $\cos 6^\circ \sin 24^\circ \cos 72^\circ$  is

- 1)  $-\frac{1}{8}$                       2)  $-\frac{1}{4}$                       3)  $\frac{1}{8}$                       4)  $\frac{1}{4}$

16. Suppose  $\theta_1$  and  $\theta_2$  are such that  $\theta_1 - \theta_2$  in  $\theta_3$  or  $\theta_4$ . If  $\sin \theta_1 + \sin \theta_2 = -\frac{21}{65}$  and

$\cos \theta_1 + \cos \theta_2 = -\frac{27}{65}$  then  $\cos\left(\frac{\theta_1 - \theta_2}{2}\right)$  is \_\_\_\_\_

- 1)  $\frac{3}{\sqrt{150}}$                       2)  $\frac{3}{\sqrt{130}}$                       3)  $-\frac{3}{\sqrt{130}}$                       4)  $-\frac{3}{\sqrt{150}}$

17. The general solution of  $\cot \frac{x}{2} - \cot x = \sec \frac{x}{2}$  is

- 1)  $2n\pi + \frac{\pi}{3}, n \in \mathbb{Z}$                       2)  $4n\pi + \frac{\pi}{3}, n \in \mathbb{Z}$                       3)  $2n\pi + \frac{2\pi}{3}, n \in \mathbb{Z}$                       4)  $4n\pi \pm \frac{2\pi}{3}, n \in \mathbb{Z}$

18. The value of  $\sin^{-1}(\sin 3) + \cos^{-1}(\cos 7) - \tan^{-1}(\tan 5)$  is

- 1)  $\pi - 1$                       2)  $\pi$                       3)  $3\pi - 1$                       4)  $2\pi - 1$

19. In  $\Delta ABC$  if  $\tan A, \tan B, \tan C$  are H.P, then  $a^2, b^2, c^2$  are in

- 1) A.P                      2) G.P                      3) H.P                      4) A.G.P

20. In  $\Delta ABC$ , if  $c = (a-b)\sec \theta$ , then  $\tan \theta =$  \_\_\_\_\_

- 1)  $\frac{2\sqrt{bc}}{b+c} \cos \frac{A}{2}$                       2)  $\frac{2\sqrt{ca}}{c+a} \cos \frac{B}{2}$                       3)  $\frac{2\sqrt{ab}}{a-b} \sin \frac{C}{2}$                       4)  $\frac{2\sqrt{bc}}{b-c} \sin \frac{A}{2}$

21. Equation  $\sqrt{(x-2)^2 + y^2} + \sqrt{(x+2)^2 + y^2} = 4$  represents

- 1) a circle                      2) a pair of lines                      3) a parabola                      4) an ellipse

22. A line L has intercepts  $a$  and  $b$  on the coordinate axes. Keeping the origin fixed, the axes are rotated through a fixed angle. Then the same line has intercepts  $p$  and  $q$  on the new axes. Then

- 1)  $a^2 + p^2 = b^2 + q^2$                       2)  $a^2 + b^2 = p^2 + q^2$   
 3)  $\frac{1}{a^2} + \frac{1}{b^2} = \frac{1}{p^2} + \frac{1}{q^2}$                       4)  $\frac{1}{a^2} + \frac{1}{p^2} = \frac{1}{b^2} + \frac{1}{q^2}$

23. If the lines  $3x + y - 4 = 0$ ,  $x - \alpha y + 10 = 0$ ,  $\beta x + 2y + 4 = 0$  and  $3x + y + k = 0$  represents the sides of a square, then  $\alpha\beta(k+4)^2$  is

- 1) -256                      2) -512                      3) -128                      4) -1024

24. For  $\lambda, \mu \in \mathbb{R}$ ,  $(x-2y-1) + \lambda(3x+2y-11) = 0$  and  $(3x+4y-11) + \mu(-x+2y-3) = 0$  represent two families of lines. If the equations of the line common to both the families is  $ax + by - 5 = 0$ . Then  $2a + b =$  \_\_\_\_\_

25. 1) 0                      2) 1                      3) 4                      4) 3  
 $L_1 \equiv 2x + y - 3 = 0$  and  $L_2 \equiv ax + by + c = 0$  are two equal sides of an isosceles triangle. If  $L_3 \equiv x + 2y + 1 = 0$  is the third side of this triangle and  $(5, 1)$  is a point on  $L_2 = 0$  then  $\frac{b^2}{|ac|}$  is
26. 1)  $\frac{|2|}{2}$                       2)  $\frac{49}{52}$                       3)  $\frac{81}{49}$                       4)  $\frac{25}{4}$   
Area of the triangle bounded by the lines given by the equations  $12x^2 - 20xy + 7y^2 = 0$  and  $x + y - 1 = 0$  is
27. 1)  $\frac{8}{29}$                       2)  $\frac{8}{39}$                       3)  $\frac{4}{29}$                       4)  $\frac{4}{39}$   
The length of the internal bisector of angle A in  $\triangle ABC$  with vertices  $A(4, 7, 8), B(2, 3, 4)$  and  $C(2, 5, 7)$  is
28. 1)  $\frac{1}{3}\sqrt{29}$                       2)  $\frac{2}{3}\sqrt{29}$                       3)  $\frac{2}{3}\sqrt{34}$                       4)  $\frac{4}{3}\sqrt{34}$   
If the distance between the planes  $2x + y + z + 1 = 0$  and  $2x + y + z + \alpha = 0$  is 3 units, then product of all possible values of  $\alpha$  is
29. 1) -43                      2) 43                      3) 53                      4) -53  
If the angle  $\theta$  between the line  $\frac{x+1}{1} = \frac{y-1}{2} = \frac{z-2}{2}$  and the plane  $2x - y + \sqrt{\lambda}z + 4 = 0$  is such that  $\sin \theta = \frac{1}{3}$ , then the value of  $\lambda$  is
30. 1)  $\frac{3}{5}$                       2)  $\frac{5}{4}$                       3)  $\frac{5}{3}$                       4)  $\frac{4}{3}$   
If  $\lim_{x \rightarrow 0} \frac{x^2 - a - \log(1+x)}{\sin x} = 0$  then  $a =$  \_\_\_\_\_
31. 1) 2                      2) 0                      3) -1                      4) 1  
 $\lim_{\theta \rightarrow \frac{\pi}{2}} \frac{8 \tan^4 \theta + 4 \tan^2 \theta + 5}{(3 - 2 \tan \theta)^4}$
32. 1)  $-\frac{1}{2}$                       2)  $\frac{1}{2}$                       3) -4                      4) 1  
If  $f(x) = \begin{cases} \frac{\sqrt{a^2 - ax + x^2} - \sqrt{x^2 + ax + a^2}}{\sqrt{a+x} - \sqrt{a-x}} & ; x \neq 0 \\ K & ; x = 0 \end{cases}$ ,  $x \neq 0$  is continuous at  $x = 0$ , then  $K =$  \_\_\_\_\_
33. 1)  $-\sqrt{a}$                       2)  $\sqrt{a}$                       3) -1                      4)  $a + \sqrt{a}$   
 $f(x) = \frac{1}{1 + \frac{1}{x}}, g(x) = \frac{1}{1 + \frac{1}{f(x)}}$  then  $g'(2) =$
34. 1)  $\frac{1}{5}$                       2)  $\frac{1}{25}$                       3) 5                      4)  $\frac{1}{16}$   
 $\frac{d}{dx} (e^{x^e} + x^{e^x} + e^{x^x}) =$
- 1)  $e^{x^e} + x^{e^x} + e^{x^x}$   
2)  $x^2 e^{x^e} + e^x x^{e^x} + x^x e^{x^x}$   
3)  $e e^{x^e} x^{e-1} + e^{e^x} e^x \left( \frac{1}{x} + \log x \right) + e^{x^x} x^x (1 + \log x)$   
4) None

35. If  $f(x) = \tan x + 2 \tan 2x + 2^2 \tan(2^2 x) + \dots + 2^{n-1} \tan(2^{n-1} x) + 2^n \cot(2^n x)$  then  $f'\left(\frac{\pi}{4}\right) =$
- 1) 0                                      2) 1                                      3) 2                                      4) -2
36. If the curves  $x^2 + py^2 = 1$  and  $qx^2 + y^2 = 1$  are orthogonal to each other, then
- 1)  $p - q = 2$                               2)  $\frac{1}{p} - \frac{1}{q} = 2$                               3)  $\frac{1}{p} + \frac{1}{q} = -2$                               4)  $\frac{1}{p} + \frac{1}{q} = 2$
37. The volume of a metal hollow sphere is constant. If the outer radius is increasing at the rate of  $\frac{1}{4}$  cm per sec. The rate at which the inner radius is increasing when the radii are 8 cm and 4 cm respectively is
- 1) 4 cm/sec                              2) 3 cm/sec                              3) 2 cm/sec                              4) 1 cm/sec
38. The greatest area of a right angled triangle of given perimeter  $p$  is
- 1)  $\frac{p^2}{2}$                                       2)  $\frac{p^2}{2(2+\sqrt{2})^2}$                               3)  $\sqrt{2}$                                       4)  $2p^2$
39. The constant C of Lagrange's theorem for  $f(x) = \frac{x}{x-1}$  in  $[2, 4]$  is
- 1) 1                                      2)  $\sqrt{3}$                                       3)  $\sqrt{3} + 1$                                       4)  $\sqrt{3} + 2$
40. The function  $\frac{\log x}{x}$  is increasing in
- 1)  $(1, 2e)$                               2)  $(0, e)$                                       3)  $(2, 2e)$                                       4)  $\left(\frac{1}{e}, 2e\right)$
41. If  $\omega$  is the complex cube roots of unity, then  $\frac{a+b\omega+c\omega^2}{c+a\omega+b\omega^2} + \frac{a+b\omega+c\omega^2}{b+c\omega+a\omega^2}$  is
- 1) 2                                      2) -2                                      3) 1                                      4) -1
42. The product of all the values of  $(\sqrt{3} - i)^{2/5}$  is
- 1)  $2(\sqrt{3} - i)$                               2)  $2(\sqrt{3} + i)$                               3)  $2(1 - \sqrt{3}i)$                               4)  $2(1 + \sqrt{3}i)$
43. If  $z_1 = \sqrt{3} + i\sqrt{3}$  and  $z_2 = \sqrt{3} + i, \left(\frac{z_1}{z_2}\right)^{50} = x + iy$ , then the point  $(x, y)$  lie in
- 1) First Quadrant                              2) Second Quadrant                              3) Third Quadrant                              4) Fourth Quadrant
44.  $x$  and  $y$  are two complex numbers such  $|x| = |y| = 1$ . If  $\text{Arg}(x) = 2\alpha, \text{Arg}(y) = 3\beta$  and  $\alpha + \beta = \frac{\pi}{36}$ , then  $x^6 y^4 + \frac{1}{x^6 y^4} =$  \_\_\_\_\_
- 1) 0                                      2) -1                                      3) 1                                      4)  $\frac{1}{2}$
45. If  $\tan A$  and  $\tan B$  are the roots of  $x^2 - px + q = 0$ , then the value of  $\sin^2(A+B)$  is
- 1)  $\frac{p^2}{p^2 + (1-q)^2}$                               2)  $\frac{p^2}{p^2 + q^2}$                                       3)  $\frac{q^2}{p^2 + (1-q)^2}$                                       4)  $\frac{p^2}{(p+q)^2}$
46. The product of real roots of the equation  $|x|^{6/5} - 26|x|^{3/5} - 27 = 0$  is
- 1)  $-3^{10}$                                       2)  $-3^{12}$                                       3)  $-3^{12/5}$                                       4)  $-3^{21/5}$
47. If  $x$  is real, then the value of  $\frac{x^2 - 3x + 4}{x^2 + 3x + 4}$  lies in the interval
- 1)  $\left[\frac{1}{3}, 3\right]$                                       2)  $\left[\frac{1}{5}, 5\right]$                                       3)  $\left[\frac{1}{6}, 6\right]$                                       4)  $\left[\frac{1}{7}, 7\right]$

48. If  $mx^2 + 7xy - 3y^2 + 4x + 7y + 2$  is resolvable into two linear factors, then  $m$  is  
 1) 7                                      2) 4                                      3) 2                                      4) -5
49. The number of different permutations that can be form by taking 4 letters at a time from the letters of the word "REPETITION" is  
 1) 1380                                      2) 1218                                      3) 1398                                      4) 1286
50. The number of ways in which 6 distinct things cab be distributed into 2 boxes so that no box is empty is  
 1) 36                                      2) 64                                      3) 62                                      4) 64
51. Number of ways in which the number 831600 can be split into two factors which are relatively prime is  
 1) 8                                      2) 64                                      3) 32                                      4) 16
52. If 5 letters are to be placed in 5-addressed envelopes, then the probability that at least one letter is placed in the wrongly addressed envelope is  
 1)  $\frac{1}{5}$                                       2)  $\frac{1}{120}$                                       3)  $\frac{4}{5}$                                       4)  $\frac{119}{120}$
53. If two number  $x$  and  $y$  are chosen one after the other at random with replacement from the set of numbers  $\{1, 2, 3, \dots, 10\}$ , then the probability that  $|x^2 - y^2|$  is divisible by 6 is  
 1)  $\frac{8}{25}$                                       2)  $\frac{6}{25}$                                       3)  $\frac{3}{10}$                                       4)  $\frac{13}{50}$
54. Bag A contains 2 white and 3 red balls and bag B contains 4 white and 5 red balls. If one ball is drawn at random from one of the bags and is found to be red, then the probability that it was drawn from the bag B is  
 1)  $\frac{23}{54}$                                       2)  $\frac{25}{51}$                                       3)  $\frac{25}{52}$                                       4)  $\frac{27}{55}$
55. In a binomial distribution  $B(n, p)$ , the sum and product of the mean and the variance are 5 and 6 respectively, then  $B(n + p - q) =$  \_\_\_  
 1) 50                                      2) 53                                      3) 52                                      4) 51
56. If  $m$  and  $M$  denote the mean deviations about mean and about median respectively of the data 20, 5, 15, 2, 7, 3, 11 then the mean deviation about mean of  $m$  and  $M$  is  
 1)  $\frac{1}{7}$                                       2)  $\frac{38}{7}$                                       3)  $\frac{36}{7}$                                       4)  $\frac{37}{7}$
57. The variance of the first 10 natural numbers which are multiples of 3 is  
 1) 53                                      2) 73                                      3) 52.5                                      4) 74.25
58. If  $\frac{x^4}{(x^2 + 1)(x - 2)} = f(x) + \frac{Ax + B}{x^2 + 1} + \frac{C}{x - 2}$ , then  $f(14) + 2A - B$   
 1) 5C                                      2) 4C                                      3) 6C                                      4) 7C
59. For  $|x| < \frac{1}{2}$ , the coefficient of  $x$  in the expansion of  $\frac{(1 - 4x)^2 (1 - 2x^2)^{\frac{1}{2}}}{(4 - x)^{\frac{3}{2}}}$  is  
 1)  $\frac{61}{64}$                                       2)  $-\frac{61}{64}$                                       3)  $\frac{69}{64}$                                       4)  $-\frac{69}{64}$
60. The coefficient of  $xy^2z^3$  in the expansion of  $(x - 2y + 3z)^6$  is  
 1) 6480                                      2) 3240                                      3) 1620                                      4) 810
61. If  $2x - 3y + 3 = 0$  and  $x + 2y + k = 0$  are conjugate lines with respect to the circle  $S \equiv x^2 + y^2 + 8x - 6y - 24 = 0$ , then the length of the tangent drawn from the point  $\left(\frac{k}{4}, \frac{k}{3}\right)$  is  
 1) 7                                      2) 1                                      3) 12                                      4) 24
62. If  $(a, b)$  is the midpoint of the chord  $2x - y + 3 = 0$  of the circle  $x^2 + y^2 + 6x - 4y + 4 = 0$ , then  $2a + 3b =$  \_\_\_

63. If  $m_1$  and  $m_2$  are the slopes of the direct common tangents drawn to the circles  $x^2 + y^2 - 2x - 8y + 8 = 0$  and  $x^2 + y^2 - 8x + 15 = 0$ , then  $m_1 + m_2 =$  \_\_\_\_\_
- 1)  $-1$                       2)  $0$                       3)  $1$                       4)  $3$
- 1)  $-\frac{24}{5}$                       2)  $\frac{12}{5}$                       3)  $\frac{24}{5}$                       4)  $-\frac{12}{5}$
64.  $(1, k)$  is a point on the circle passing through the points  $(-1, 1), (0, -1)$  and  $(1, 0)$ . If  $K \neq 0$ , then  $K =$  \_\_\_\_\_
- 1)  $\frac{1}{2}$                       2)  $\frac{1}{3}$                       3)  $-\frac{1}{3}$                       4)  $-\frac{1}{2}$
65. If the circle  $x^2 + y^2 + 4x - 6y + c = 0$  bisects the circumference of the circle  $x^2 + y^2 - 6x + 4y - 12 = 0$ , then  $c$  is
- 1)  $16$                       2)  $24$                       3)  $-42$                       4)  $-62$
66. If a tangent of slope 2 to the ellipse  $\frac{x^2}{a^2} + \frac{y^2}{b^2} = 1$  touches the circle  $x^2 + y^2 = 4$ , then the maximum value of  $ab$  is
- 1)  $4$                       2)  $12$                       3)  $5$                       4)  $7$
67. The product of perpendiculars from the two foci of the ellipse  $\frac{x^2}{9} + \frac{y^2}{25} = 1$  on the tangent at any point on the ellipse is
- 1)  $6$                       2)  $7$                       3)  $8$                       4)  $9$
68. If the equation  $\frac{x^2}{7-k} + \frac{y^2}{5-k} = 1$  represents a hyperbola, then
- 1)  $5 < k < 7$                       2)  $k < 5$  (or)  $k > 7$                       3)  $k > 5$                       4)  $k \neq 5, k \neq 7, -\infty < k < \infty$
69. Equation of the line touching both the parabolas  $y^2 = 4x$  and  $x^2 = -32y$  is
- 1)  $x + 2y + 4 = 0$                       2)  $2x + y - 4 = 0$                       3)  $x - 2y - 4 = 0$                       4)  $x - 2y + 4 = 0$
70. P and Q are the extremities of a focal chord of the parabola  $y^2 = 4ax$ . If  $P = (9, 9)$  and  $Q = (p, q)$ , then  $p - q$  is
- 1)  $-\frac{27}{16}$                       2)  $\frac{63}{16}$                       3)  $\frac{45}{16}$                       4)  $\frac{81}{6}$
71.  $\int \frac{dx}{4 + 3 \cot x} dx$  is \_\_\_\_\_
- 1)  $-\frac{3}{25} \log|4 + 3 \cot x| + \frac{4}{25} x + c$                       2)  $\frac{3}{25} \log|4 \sin x + 3 \cos x| + \frac{4}{25} x + c$
- 3)  $\frac{4}{25} \log|4 \sin x + 3 \cos x| - \frac{3}{25} x + c$                       4)  $\frac{4}{25} \log|4 + 3 \cot x| - \frac{3}{25} x + c$
72.  $\int (\log x)^3 dx$  is
- 1)  $(\log x)^3 - 3(\log x)^2 + 6 \log x - 6 + c$                       2)  $x \left[ (\log x)^3 - 3(\log x)^2 + 6 \log x - 6 \right] + c$
- 3)  $(x \log x)^3 + 3(\log x)^2 + 6x \log x - 6 + c$                       4)  $\frac{1}{x} \left[ (\log x)^3 - 3(\log x)^2 + 6 \log x - 6 \right] + c$
73. If  $\int \frac{\sin x \cos x}{\sqrt{\cos^4 x - \sin^4 x}} dx = -\frac{f(x)}{2} + c$ , then domain of  $f(x)$  is
- 1)  $[2n\pi, (2n+1)\pi], n \in W$                       2)  $\left[ (4n-1)\frac{\pi}{2}, (4n+1)\frac{\pi}{2} \right], n \in W$
- 3)  $\left[ (4n-1)\frac{\pi}{4}, (4n+1)\frac{\pi}{4} \right], n \in W$                       4)  $\left[ 2n\left(\frac{\pi}{4}\right), (2n+1)\frac{\pi}{4} \right], n \in W$

74.  $\int_{-\frac{\pi}{8}}^{\frac{\pi}{8}} \frac{\sin^4(4x)}{1+e^{4x}} dx$  is  
 1)  $\frac{3\pi}{128}$                       2)  $\frac{3\pi}{256}$                       3)  $\frac{3\pi}{64}$                       4)  $\frac{3\pi}{32}$
75.  $\int_0^{16} \frac{\sqrt{x}}{1+\sqrt{x}} dx$  is  
 1)  $8+2\log 2$                       2)  $8+\log 2$                       3)  $8+2\log 5$                       4)  $4+\log 5$
76.  $\int_{-\frac{3}{4}}^{\frac{\pi-6}{8}} \log(\sin(4x+3)) dx$   
 1)  $-\frac{\pi}{2}\log 2$                       2)  $-\frac{\pi}{8}\log 2$                       3)  $-\frac{\pi}{14}\log 2$                       4)  $-\frac{\pi}{28}\log 2$
77. Order and degree of the D.E  $\frac{d^3y}{dx^3} = \left[1 + \left(\frac{dy}{dx}\right)^2\right]^{\frac{5}{2}}$  are  
 1) 5, 2                      2) 3, 5                      3) 3, 2                      4) 2, 3
78. The solutions of D.E  $(x+2y^3)\frac{dy}{dx} = y$  is  
 1)  $x = y(2xy+c)$                       2)  $x = y(y^2+c)$                       3)  $y = x(x^2+c)$                       4)  $xy = \frac{y^4}{2} + c$
79. If  $y = \sin x + A\cos x$  is the general solution of a D.E  $\frac{dy}{dx} + f(x).y = \sec x$ , then I.F of D.E is  
 1)  $\sec x$                       2)  $\tan x$                       3)  $\cos x$                       4)  $\sin x$
80. The area of the region described by  $A = \{(x, y) : x^2 + y^2 \leq 1 \text{ and } y^2 \leq 1-x\}$  is  
 1)  $\frac{\pi}{2} - \frac{2}{3}$                       2)  $\frac{\pi}{2} + \frac{2}{3}$                       3)  $\frac{\pi}{2} + \frac{4}{3}$                       4)  $\frac{\pi}{2} - \frac{4}{3}$

### PHYSICS

81. Matching the following
- |                         |                           |  |
|-------------------------|---------------------------|--|
| A) Thermal conductivity | I) $[MLT^{-3}K^{-1}]$     |  |
| B) Boltzmann constant   | II) $[M^0L^2T^2K^{-1}]$   |  |
| C) Latent heat          | III) $[ML^2T^{-2}K^{-1}]$ |  |
| D) Special heat         | IV) $[M^0L^2T^2]$         |  |
- |    | A   | B   | C   | D   |
|----|-----|-----|-----|-----|
| 1) | I   | III | IV  | II  |
| 2) | I   | II  | IV  | III |
| 3) | III | II  | I   | IV  |
| 4) | II  | I   | III | IV  |
82. The percentage error in the measurement of mass and velocity are 3% and 4%, respectively. The percentage error in the measurement of kinetic energy is  
 1) 11%                      2) 12%                      3) 14%                      4) 8%
83. One second after projection, a projectile is travelling in a direction inclined at  $45^\circ$  to horizontal. After two more seconds, it is travelling horizontally. Then, the magnitude of velocity of the projectile is ( $g = 10ms^{-2}$ )  
 1)  $10\sqrt{13}ms^{-1}$                       2)  $11ms^{-1}$                       3)  $10\sqrt{2}ms^{-1}$                       4)  $20ms^{-1}$

84. A car travelling at 80 kmph can be stopped at distance of 60m by applying brakes. If the same car travels at 160 kmph and the same braking force is applied, the stopping distance  
 1) 240m                      2) 170m                      3) 360m                      4) 480m
85. A block of mass 1.5 kg kept on a rough horizontal surface is given velocity of  $10\text{ms}^{-1}$ . If the block comes to rest after travelling a distance of 12.5m, the coefficient of kinetic friction between the surface and the block is (acceleration due to gravity =  $10\text{ms}^{-2}$ )  
 1) 0.2                      2) 0.4                      3) 0.8                      4) 0.6
86. A 4kg mass is suspended as shown in figure. All pulleys are frictionless and spring constant k is  $8 \times 10^3 \text{Nm}^{-1}$ . The extension in spring is ( $g = 10\text{ms}^{-2}$ )

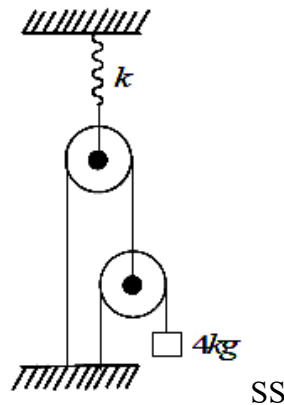

- 1) 2 mm                      2) 2 cm                      3) 4 cm                      4) 4 mm
87. Two objects having masses 1:4 ratio are at rest. When both of them are subjected to same force separately, they achieved same kinetic energy during times  $t_1$  and  $t_2$  respectively. Then, ratio of  $\frac{t_2}{t_1}$  is  
 1) 4                      2) 2                      3) 2.5                      4) 1
88. An object of mass m is projected with an initial velocity u with angle of  $\theta$  with the horizontal. The average power delivered by gravity in reaching the highest point  
 1)  $\frac{mgu \sin^2 \theta}{2}$                       2)  $\frac{mu^2 \sin^2 \theta}{2g}$                       3)  $\frac{mg \sin^2 \theta}{2u}$                       4)  $\frac{mgu \sin \theta}{2}$
89. The mass of a solid cylinder and hollow cylinder are 3.2 kg and 1.6 kg respectively. Both the solid and hollow cylinders start from rest from the top of an inclined plane and roll down without slipping. If both the cylinder have equal radius and acceleration of solid cylinder is  
 1)  $2\text{ms}^{-2}$                       2)  $9\text{ms}^{-2}$                       3)  $6\text{ms}^{-2}$                       4)  $3\text{ms}^{-2}$
90. The value of acceleration due to gravity at a height of  $4R_E$  from surface of earth is ( $R_E$  is radius of earth and acceleration due to gravity on the surface of the earth =  $10\text{ms}^{-2}$ )  
 1)  $0.2\text{ms}^{-2}$                       2)  $0.3\text{ms}^{-2}$                       3)  $0.4\text{ms}^{-2}$                       4)  $3\text{ms}^{-2}$
91. A spherical ball of volume  $2000 \text{cm}^3$  is subjected to a hydraulic pressure of 15 atm. If the change in volume is  $5 \times 10^{-2} \text{cm}^3$ , the bulk modulus of the material of the spherical ball is ( $1 \text{atm} = 10^5 \text{N/m}^2$ )  
 1)  $6 \times 10^{10} \text{Nm}^{-2}$                       2)  $2 \times 10^{10} \text{Nm}^{-2}$                       3)  $5 \times 10^{10} \text{Nm}^{-2}$                       4)  $15 \times 10^{10} \text{Nm}^{-2}$
92. The gauge pressure at a depth of 500 m in a sea is (Density of sea water is  $1025 \text{kg m}^{-3}$  and  $g = 10\text{ms}^{-2}$ )  
 1) 1025Pa                      2) 512500Pa                      3) 20000Pa                      4) 15000Pa
93. A rod is found to be 0.05 cm longer at  $40^\circ \text{C}$  than it is at  $10^\circ \text{C}$ . The length of the rod at  $0^\circ \text{C}$  is (Coefficient of linear expansion of the material of the rod =  $1.5 \times 10^{-5} \text{ }^\circ\text{C}^{-1}$ )  
 1) 101.1cm                      2) 120.2cm                      3) 105.1cm                      4) 111.1cm
94. Heat energy absorbed by a system going through the cyclic process shown in the figure is

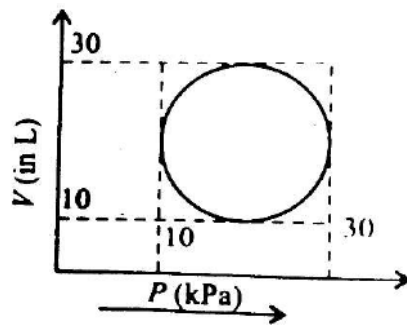

- 1)  $10^7 \pi J$                       2)  $10^4 \pi J$                       3)  $10^2 \pi J$                       4)  $10^{-3} \pi J$
95. The number of degrees of freedom of a monatomic molecules is  
 1) 2                                      2) 1                                      3) 0                                      4) 3
96. The relation between the force (F in Newton) acting on a particle executing simple harmonic motion and the displacement of the particle (y in meter) is  $500F + \pi^2 y = 0$ . If the mass of the particle is 2g. the time period of oscillation of the particle is  
 1) 8s                                      2) 6 S                                      3) 2 S                                      4) 4 S
97. As shown in the figure, two blocks of masses  $m_1$  and  $m_2$  are connected to spring of force constant k. The blocks are slightly displaced in opposite direction to  $x_1, x_2$  distance and released. If the system executes simple harmonic motion, then the frequency of the system ( $\omega$ ) is

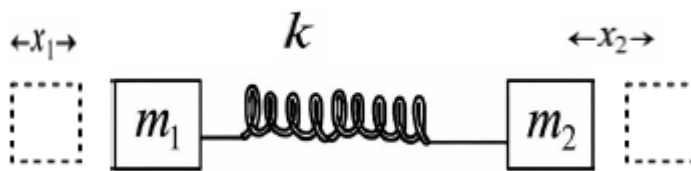

- 1)  $\left(\frac{1}{m_1} + \frac{1}{m_2}\right)k^2$                       2)  $\sqrt{\left(\frac{1}{m_1} + \frac{1}{m_2}\right)k^2}$                       3)  $\sqrt{\left(\frac{1}{m_1} + \frac{1}{m_2}\right)}$                       4)  $\sqrt{\left(\frac{1}{m_1} + \frac{1}{m_2}\right)k}$
98. During the propagation of a longitudinal wave, in the region of compression and rarefactions  
 1) Density varies                                      2) Density remains constant  
 3) There is heat transfer                                      4) Boyle's law is obeyed
99. A body is suspended from a sting of length 1 m and mass 2 g. The mass of the body to produce a fundamental mode of 100Hz frequency in the sting is (Acceleration due to gravity =  $10ms^{-2}$ )  
 1) 80 g                                      2) 4 kg                                      3) 400 g                                      4) 8 kg
100. Which of the following do not exist?  
 1) Electric dipoles                                      2) Electric monopoles  
 3) Magnetic monopoles                                      4) Magnetic dipoles
101. A block of mass m and charge q is connected to a point O with an inextensible sting. This system is on a horizontal table. An electric field E is applied perpendicular to the string and in the plane of the horizontal table. The tension in the sting when it becomes parallel to the electric field is  
 1)  $qE$                                       2)  $2qE$                                       3)  $\frac{3qE}{4}$                                       4)  $3qE$
102. The drift velocity of electrons in a conducting wire connected to a cell is  $V_d$ . If the length of the wire is doubled and area of cross-section is halved, then the drift velocity of electrons becomes.  
 1)  $3V_d$                                       2)  $\frac{V_d}{4}$                                       3)  $2V_d$                                       4)  $4V_d$
103. In the circuit given below, if he bulb is to glow with maximum intensity, the value of 'R' is (neglect internal resistance of the cell)

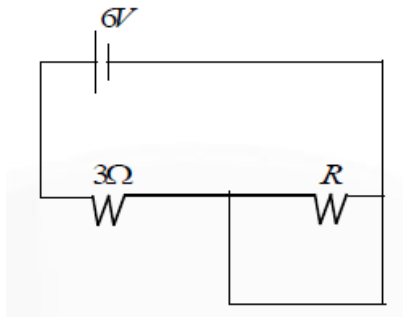

- 1)  $1.25\Omega$                       2)  $4.5\Omega$                       3)  $6\Omega$                       4)  $8.5\Omega$
104. A circular coil of 30 turns and radius 8cm carrying a current of 6 A is suspended vertically in a uniform horizontal magnetic field of magnitude 1.0 T. The field lines make an angle of  $30^\circ$  with the normal of the coil. The magnitude of the counter torque that must be applied to prevent the coil from turning is.
- 1)  $5.4N-m$                       2)  $7.2N-m$                       3)  $3.6N-m$                       4)  $1.8N-m$
105. A galvanometer has a deflection of 25 divisions for a current of 0.1A flowing through it. Then the current sensitivity of the galvanometer is
- 1) 25 div/A                      2) 250 div/A                      3) 2.5 div/A                      4) 0.25 div/A
106. A paramagnetic sample showing a net magnetization of  $0.8\text{ Am}^{-1}$ , when placed in an external magnetic field of strength 0.8T, at a temperature 5K. If the temperature is raised to 20 k, then the magnetisation becomes
- 1)  $0.8\text{ Am}^{-1}$                       2)  $0.2\text{ Am}^{-1}$                       3)  $0.1\text{ Am}^{-1}$                       4)  $0.4\text{ Am}^{-1}$
107. A pair of adjacent coils having a mutual inductance, M. The current in one coil changes from 0 to 16A in 0.3s and the change of flux linkage with the other coil is 40Wb. The value of M is
- 1) 0.4 H                      2) 0.12 H                      3) 2.5 H                      4) 8.3H
108. An electric generator is based on
- 1) Faraday's law of electromagnetic induction  
 2) Motion of charged particles in an electromagnetic field  
 3) Fission of uranium by slow neutrons  
 4) Newton's laws of motion
109. An inductor of reactance  $1\Omega$  and a resistor of resistance  $3\Omega$  are connected in series to the terminals of 10V (rms) AC source. The power dissipated in the circuit is
- 1) 33.3 W                      2) 30 W                      3) 31.6 W                      4) 20 W
110. A bulb of power 660W radiates uniformly in all directions. The pressure exerted by the radiation on the surface at a distance of 5 m is
- 1)  $5 \times 10^{-8}\text{ Pa}$                       2)  $2 \times 10^{-9}\text{ Pa}$                       3)  $7 \times 10^{-9}\text{ Pa}$                       4)  $\frac{3}{\pi} \times 10^{-8}\text{ Pa}$
111. The radii of curvature of a double convex lens are 4 cm and 8 cm. if the refractive index of a material of the lens is 1.5. the focal length of lens is nearly
- 1) 16 cm                      2) 12.11 cm                      3) 7.33 cm                      4) 5.33 cm
112. Light of wavelength 30nm in medium A enters into medium B through a plane surface. If the frequency of light is  $5 \times 10^{14}\text{ Hz}$  and the ratio of speed in medium A to the in medium B is 4/5, the absolute refractive index of medium B is
- 1) 1.6                      2) 1.5                      3) 1.3                      4) 1.5
113. The limit of resolution of an oil immersion objective microscope of numerical aperture 0.8 for light of wavelength  $0.6\ \mu\text{m}$  is
- 1)  $\frac{1.5}{8}\ \mu\text{m}$                       2)  $\frac{3}{8}\ \mu\text{m}$                       3)  $\frac{5}{8}\ \mu\text{m}$                       4)  $\frac{7}{8}\ \mu\text{m}$
114. The voltage applied to an electron microscope of produce electrons of wavelength  $0.50\ \text{Å}$  is
- 1) 602 V                      2) 50 V                      3) 138 V                      4) 812 V
115. The study of photoelectric effect is useful in understanding
- 1) Quantization of charge                      2) Quantization of energy  
 3) Conservation of energy                      4) Conservation of kinetic energy
116. Assertion (A): The impact parameter for  $\alpha$ -Particle by  $180^\circ$  is zero

Reason (R): Zero impact parameter means that the  $\alpha$ -particles tend to hit the centre of the nucleus

- 1) Both A and R are true and R is a correct explanation of A
  - 2) Both A and R are true and R is not a correct explanation of A
  - 3) A is true but R is false
  - 4) A is false but R is true
117. The half-life of a radioactive sample is  $T$ . The fraction of the initial mass of the sample that decays in an interval  $T/2$  is
- 1)  $\frac{1}{\sqrt{2}}$
  - 2)  $\sqrt{2}$
  - 3)  $\frac{(\sqrt{2}-1)}{\sqrt{2}}$
  - 4)  $\frac{(\sqrt{2}+1)}{\sqrt{2}}$
118. The current amplification factor and the collector current in a CE transistor circuit are 100 and 2.2 mA respectively. Then the base current is
- 1)  $0.22 \mu A$
  - 2)  $22 \mu A$
  - 3)  $220 \mu A$
  - 4)  $2.2 \mu A$
119. The energy of photon in a monochromatic light of wavelength 621 nm matches with the band gap of a semiconducting material. Then the minimum energy required to create an electron-hole pair from the semiconductor is (Take,  $hc = 1242 eV - nm$ . Where  $h$  is Planck's constant and  $c$  is speed of light in vacuum)
- 1) 3.4eV
  - 2) 1.7eV
  - 3) 2eV
  - 4) 2.2eV
120. A TV tower has a height 160m. Its coverage range is nearly (Earth's radius,  $R_e = 6400 km$ )
- 1) 45255m
  - 2) 55265m
  - 3) 452.55km
  - 4) 552.65m

### CHEMISTRY

121. If  $\lambda_0$  and  $\lambda$  threshold wavelength and wavelength of incident light, the velocity of photoelectron ejected from the metal surface is

- 1)  $\sqrt{\frac{2h}{m}(\lambda_0 - \lambda)}$
- 2)  $\sqrt{\frac{2hc}{m}(\lambda_0 - \lambda)}$
- 3)  $\sqrt{\frac{2hc}{m} \left( \frac{\lambda_0 - \lambda}{\lambda \lambda_0} \right)}$
- 4)  $\sqrt{\frac{2h}{m} \left( \frac{1}{\lambda_0} - \frac{1}{\lambda} \right)}$

122. The plots of radial distribution functions for various orbitals of hydrogen atom against ' $r$ ' are given below.

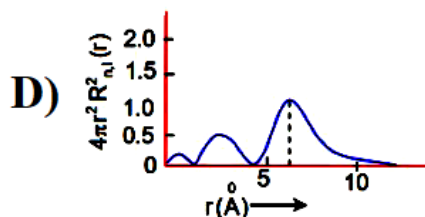
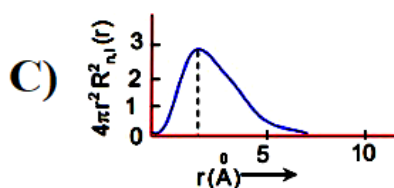
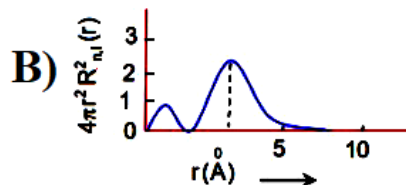
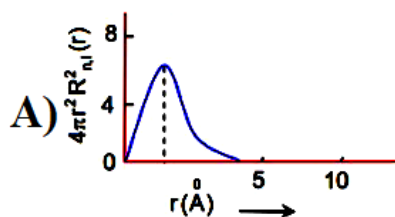

The correct plot for 3S orbital is

- 1) B
  - 2) C
  - 3) A
  - 4) D
123. Henry Moseley studied characteristic X-ray spectra of elements. The graph which represents his observation correctly is  
Given  $\nu$  = frequency of X-ray emitted  $Z$  = atomic number

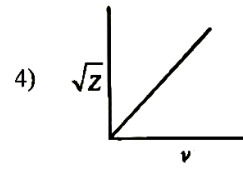
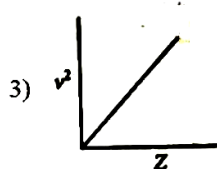
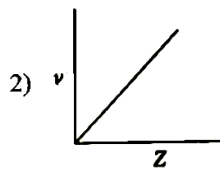
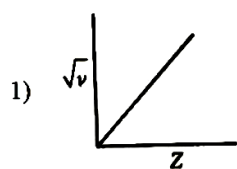

124.

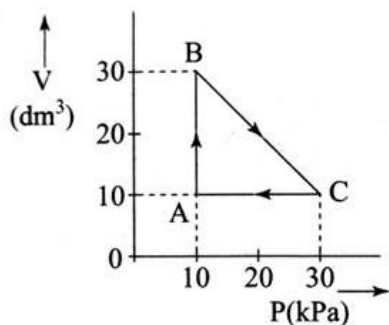

An ideal gas undergoes a cyclic transformation starting from the point A and coming back to the same point by tracing the path  $A \rightarrow B \rightarrow C \rightarrow A$  as shown in the diagram above. The total work done in the process is..... J

- 1) 200 J                      2) 300 J                      3) 250 J                      4) 350 J

125. A reaction is non-spontaneous at the freezing point of water but is spontaneous at the boiling point of water, then

- |    | $\Delta H$ | $\Delta S$ |    | $\Delta H$ | $\Delta S$ |
|----|------------|------------|----|------------|------------|
| 1) | +ve        | +ve        | 2) | -ve        | -ve        |
| 3) | -ve        | +ve        | 4) | +ve        | -ve        |

126. If solubility product of  $Zr_3(PO_4)_4$  is denoted by  $K_{sp}$  and its molar solubility is denoted by  $S$ , then which of the following relation between  $S$  and  $K_{sp}$  is

- 1)  $S = \left(\frac{K_{sp}}{144}\right)^{\frac{1}{6}}$       2)  $S = \left(\frac{K_{sp}}{6912}\right)^{\frac{1}{7}}$       3)  $S = \left(\frac{K_{sp}}{929}\right)^{\frac{1}{9}}$       4)  $S = \left(\frac{K_{sp}}{216}\right)^{\frac{1}{7}}$

127. Using the given information data in the following paper chromatogram

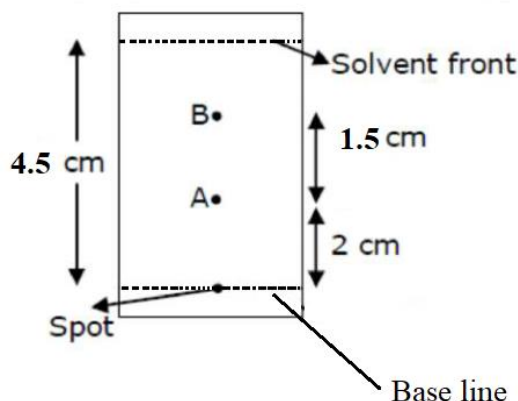
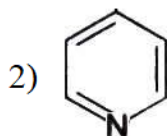
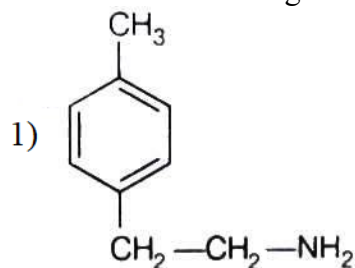

**Figure : paper chromatography for compounds A and B**

Calculate the  $R_f$  value of A and B

- 1) 0.44, 0.33                      2) 0.48, 0.38                      3) 1.44, 1.37                      4) 0.33, 0.45

128. Which of the following compound will be suitable for Kjeldahl's method for nitrogen estimation?



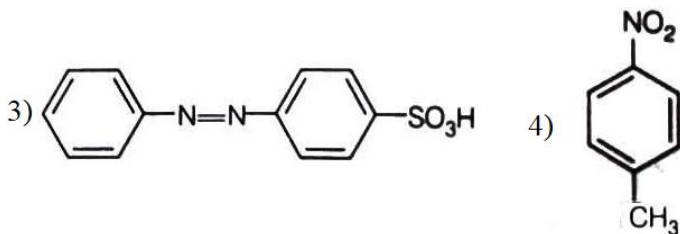

129. IUPAC name of following compound (P) is

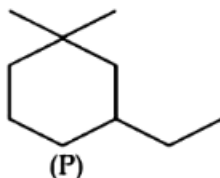

- 1) 1, 1-dimethyl, 3-ethylcyclohexane                      2) 3-ethyl-1, 1-dimethylcyclohexane  
3) 1-ethyl-3, 3-dimethylcyclohexane                      4) 1-ethyl-5, 5-dimethylcyclohexane

130. Which of the following metamer of the given compound(X)?

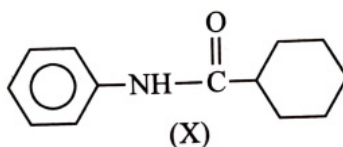

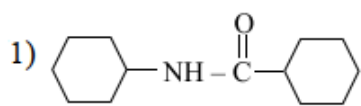
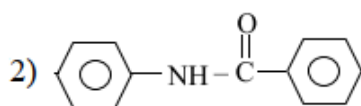
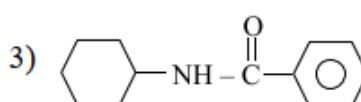
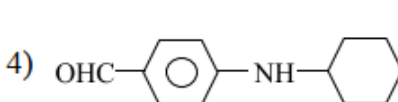
- 1)  2)   
3)  4) 

131. 'x' mg of an organic compound was analysed by Kjeldahl method. The ammonia evolved was absorbed in 50 mL of 0.5 M  $H_2SO_4$ . The unused acid required 60 mL of 0.5 M NaOH solution for complete neutralisation. If the percentage of nitrogen in the compound is 56, the value of x is  
1) 500                      2) 250                      3) 750                      4) 375

132. Identify the correct statement for the below given transformation

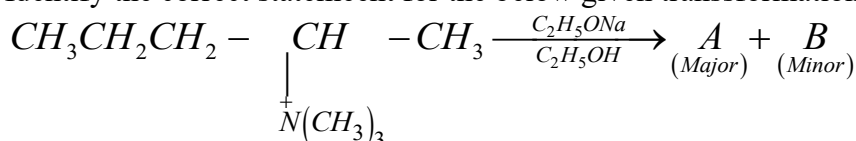

- 1)  $A - CH_3CH_2CH = CH - CH_3$   
 $B - CH_3CH_2CH_2CH = CH_2$  Saytzeff products  
2)  $A - CH_3CH_2CH = CH - CH_3$ ,  
 $B - CH_3CH_2CH_2CH = CH_2$  Hofmann products  
3)  $A - CH_3CH_2CH_2CH = CH_2$   
 $B - CH_3CH_2CH = CH - CH_2$  Hofmann products  
4)  $A - CH_3CH_2CH_2CH = CH_2$ ,  
 $B - CH_3CH_2CH = CH - CH_3$  Saytzeff Products

133. For the given reaction

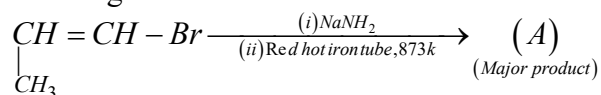

What is 'A' ?

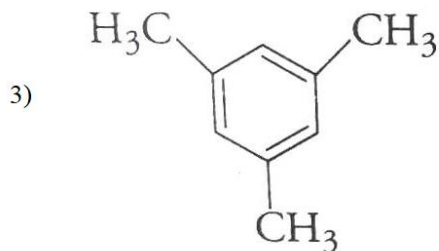
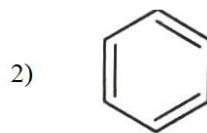
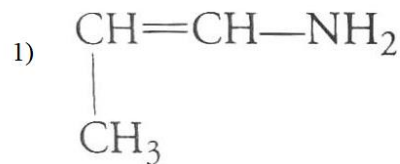

134. A graph of vapour pressure and temperature for three different liquids  $X, Y,$  and  $Z$  is shown below.

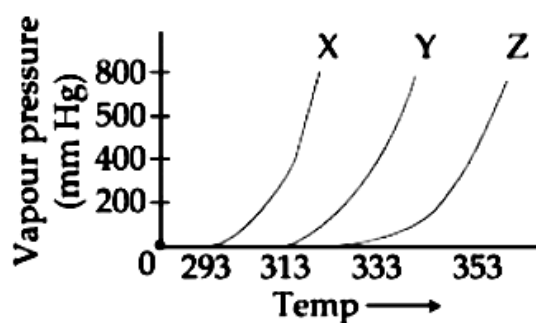

The following inference are made:

A)  $X$  has higher intermolecular interactions compared to  $Y$

B)  $X$  has lower intermolecular interactions compared to  $Y$

C)  $Z$  has lower intermolecular interactions compared to  $Y$

The correct inference (s) is/are

1) C

2) B

3) A

4) A and C

135. Which one of the following graphs between molar conductivity ( $\Delta_m$ ) versus  $\sqrt{C}$  is correct?

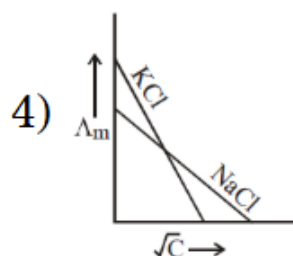
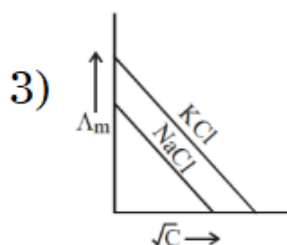
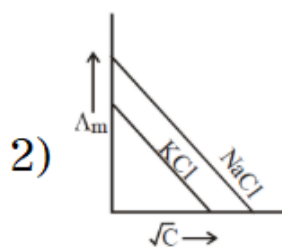
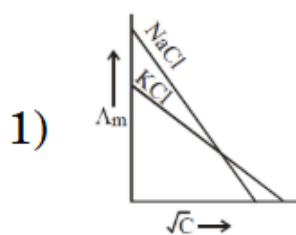

136. For the redox reaction

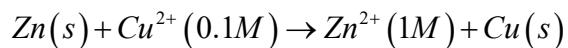

taking place in a cell,  $E_{cell}^0$  is  $1.10V$ ,  $E_{cell}$  for the cell will be  $\left(2.303 \frac{RT}{F} = 0.0591\right)$

1) 2.14V

2) 1.80V

3) 1.07V

4) 0.82V

137. Integrated rate law equation for a first order gas phase reaction is given by:  $A_{(g)} \rightarrow B_{(g)} + C_{(g)}$

(where  $p_i$  is initial pressure and  $p_t$  is total pressure at time  $t$ )

$$1) k = \frac{2.303}{t} \times \frac{p_i}{(2p_i - p_t)} \quad 2) k = \frac{2.303}{t} \times \log \frac{p_i}{(2p_i - p_t)}$$

$$3) k = \frac{2.303}{t} \times \log \frac{2p_i}{(2p_i - p_t)} \quad 4) k = \frac{2.303}{t} \times \log \frac{(2p_i - p_t)}{p_i}$$

138. A reaction has rate constant  $k = 2.4 \times 10^{-4} s^{-1}$ . Then, find the ratio of  $t_{99.9}$  to  $t_{50}$

- 1) 1                      2) 5                      3) 10                      4) 15

139. Match List – I with List- II

**List – I**

(Name of oxo acid)

- A) Hypo phosphorous acid  
B) Orthophosphoric acid  
C) Hypophosphoric acid  
D) Orthophosphorous acid

**List – II**

(Oxidation state of 'p')

- I) +5  
II) +4  
III) +3  
IV) +2  
V) +1

Choose the correct answer from the option given below

- |    | <b>A</b> | <b>B</b> | <b>C</b> | <b>D</b> |
|----|----------|----------|----------|----------|
| 1) | IV       | V        | II       | III      |
| 2) | V        | IV       | II       | III      |
| 3) | V        | I        | II       | III      |
| 4) | IV       | I        | II       | III      |

140. In which of the following arrangements, the sequence is not strictly according to the property written against it?

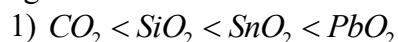

Increasing oxidising power



Increasing acid strength

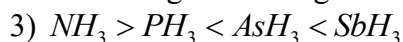

Increasing basic strength



Increasing first ionisation enthalpy

141. Which of the following is correct represents increasing order of reducing nature of hydrides.

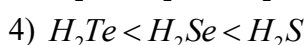
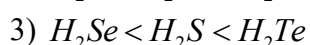

142. The shape/structure of  $[XeF_5]^-$  and  $XeO_3F_2$  respectively, are

1) Pentagonal planar and trigonal bipyramidal

2) octahedral and square pyramidal

3) trigonal bipyramidal and pentagonal planar

4) trigonal bipyramidal and trigonal bipyramidal

143. Identify the major products A and B respectively in the following set of reactions

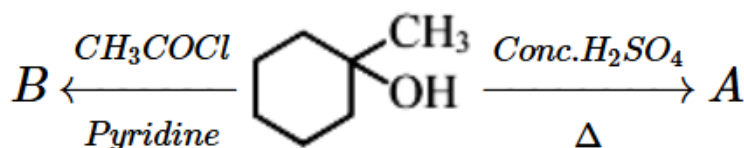

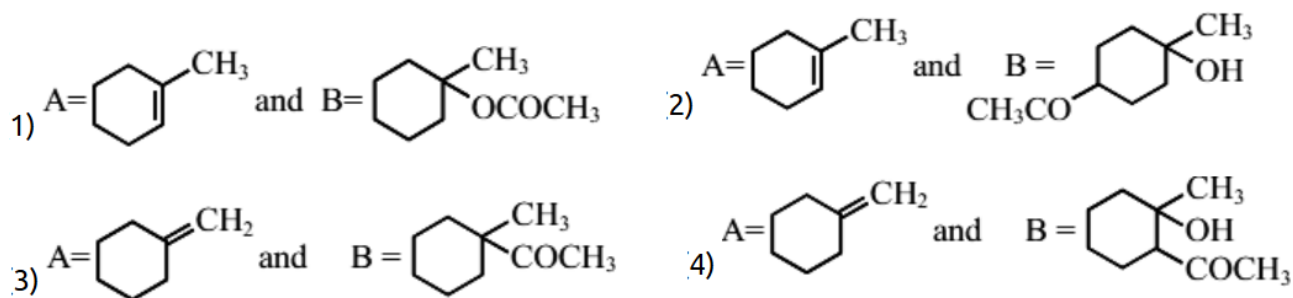

144. The IUPAC name of the following compound is

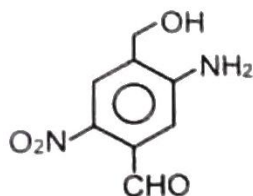

- 1) 2-nitro-4-hydroxymethyl-5-aminobenzaldehyde
- 2) 3-amino-4-hydroxymethyl-5-nitrobenzaldehyde
- 3) 5-amino-4-hydroxymethyl-2-nitrobenzaldehyde
- 4) 2-amino-2-formyl-5-hydroxymethylnitrobenzene

145. Match the catalysts to the correct processes.

Catalyst		Processes	
A) $TiCl_4$		I) Wacker processes	
B) $PdCl_2$		II) Ziegler-Natta polymerisation	
C) $CuCl_2$		III) Contact processes	
D) $V_2O_5$		IV) Deacon's processes	

	A	B	C	D
1)	II	III	IV	I
2)	III	I	II	IV
3)	III	II	IV	I
4)	II	I	IV	III

146. The pair of metal ions that can give a spin-only magnetic moment of 3.9 BM for the complex  $[M(H_2O)_6]Cl_2$ , is

- 1)  $Co^{2+}$  and  $Fe^{2+}$
- 2)  $Cr^{2+}$  and  $Mn^{2+}$
- 3)  $V^{2+}$  and  $Co^{2+}$
- 4)  $V^{2+}$  and  $Fe^{2+}$

147. The electronic configuration for neodymium is [Atomic number for neodymium 60]

- 1)  $[Xe]5f^7 7s^2$
- 2)  $[Xe]4f^4 6s^2$
- 3)  $[Xe]4f^1 5d^1 6s^2$
- 4)  $[Xe]4f^6 6s^2$

148. Which of the following is the correct structure of L-glucose?

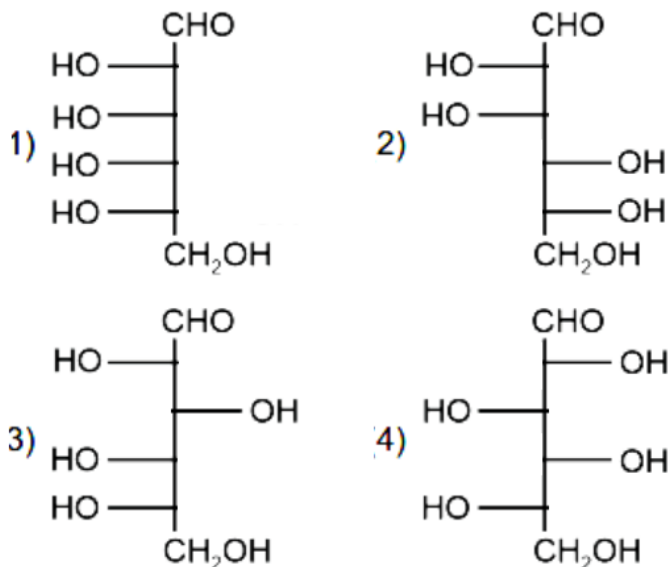

149. In the following sequence of reaction

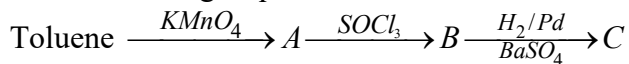

The product C is

- 1)  $\text{C}_6\text{H}_5\text{COOH}$       2)  $\text{C}_6\text{H}_5\text{CH}_3$       3)  $\text{C}_6\text{H}_5\text{CH}_2\text{OH}$       4)  $\text{C}_6\text{H}_5\text{CHO}$

150. Identify the product in the following reaction

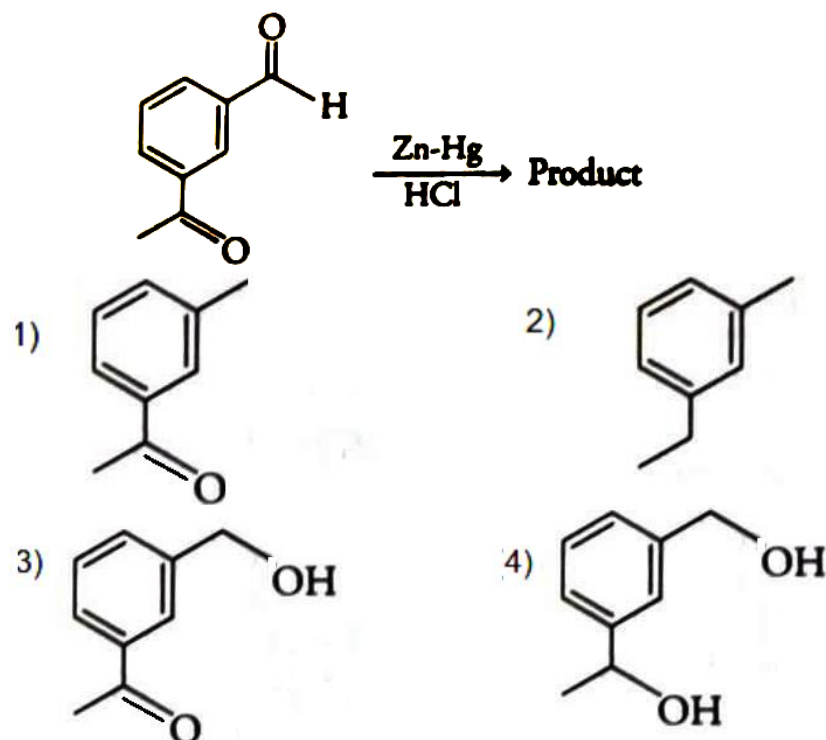

151. Combustion of glucose ( $\text{C}_6\text{H}_{12}\text{O}_6$ ) produces  $\text{CO}_2$  and water. The amount of oxygen (in g) required for the complete combustion of 900 g of glucose is [Molar mass of glucose in  $\text{g mol}^{-1} = 180$ ]

- 1) 32      2) 480      3) 800      4) 960

152. The potential energy curve for that  $\text{H}_2$  molecule as a function of internuclear distance is

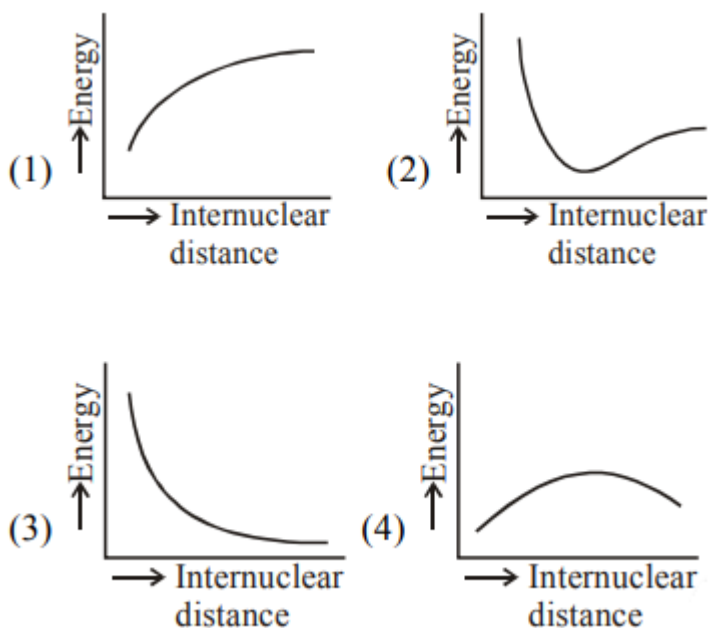

153. A compound 'X' is a weak acid and it exhibits colour change at pH close to the equivalence point during neutralisation of  $\text{NaOH}$  with  $\text{CH}_3\text{COOH}$ . Compound 'X' exists in ionised form in basic medium. The compound 'X' is

- 1) methyl orange      2) methyl red      3) phenolphthalein      4) Cerinic nitrate

154. Among the following compounds, which one is found in RNA?

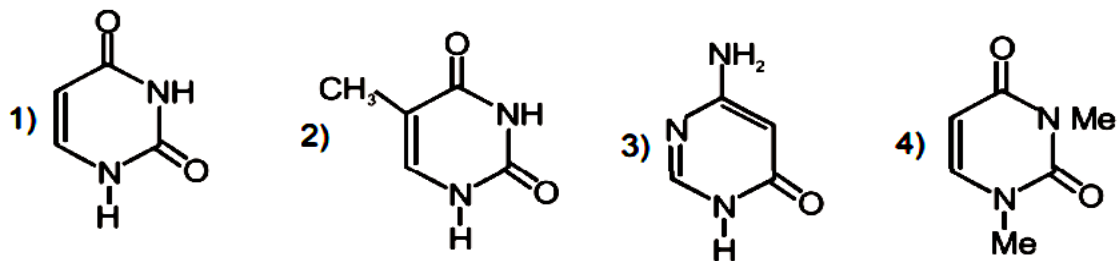

155. Thiamine and pyridoxine are also known respectively as  
 1) vitamin  $B_2$  and vitamin E      2) vitamin E and vitamin  $B_2$   
 3) vitamin  $B_6$  and vitamin  $B_2$       4) vitamin  $B_1$  and vitamin  $B_6$

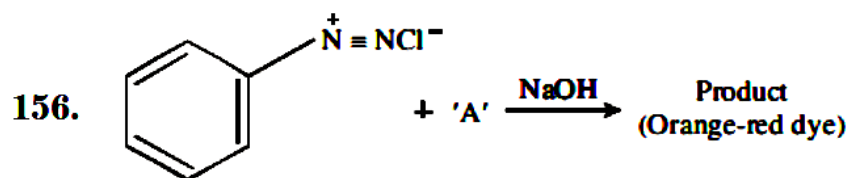

Which among the following represent reagent 'A'?

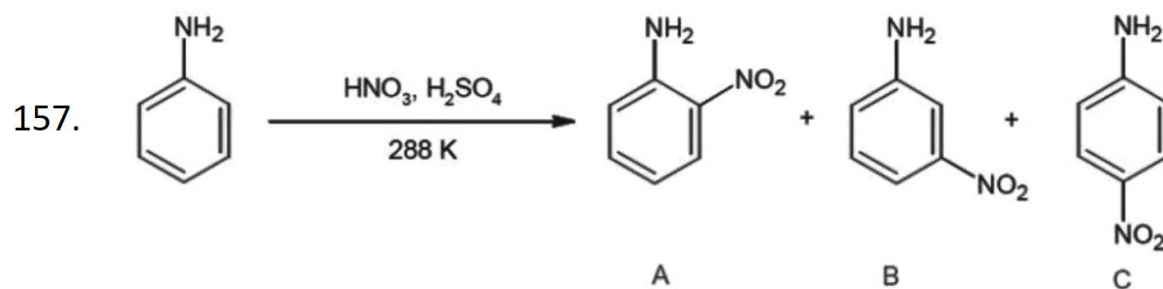
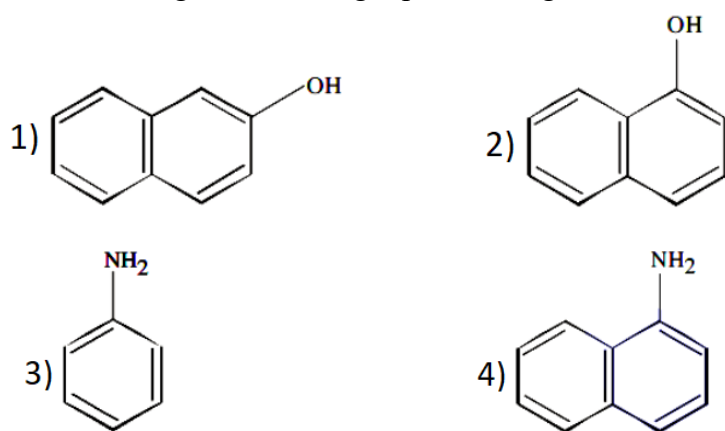

Consider the given reaction, percentage yield of

- 1)  $C > A > B$       2)  $B > C > A$       3)  $A > C > B$       4)  $C > B > A$

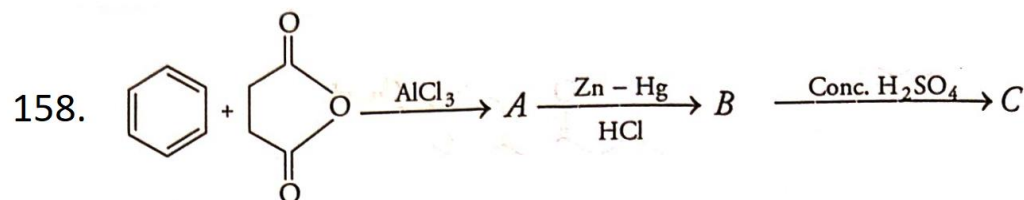

What is the structure of C?

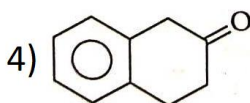
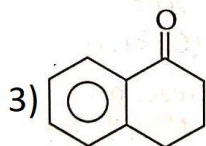
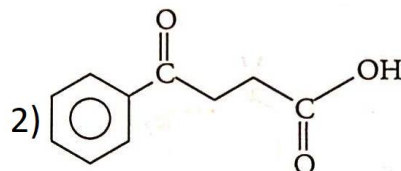
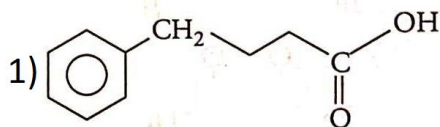

159. For a chemical reaction,  $A + B \rightarrow \text{product}$ , the order is 1 with respect to A and B

Rate $\text{mol L}^{-1}$	[A] $\text{Mol L}^{-1} \text{ s}^{-1}$	[B] $\text{mol L}^{-1}$
0.10	20	0.5
0.40	$x$	0.5
0.80	40	$y$

What is the value of  $x$  and  $y$ ?

1) 80 and 4

2) 80 and 2

3) 40 and 4

4) 160 and 4

160.

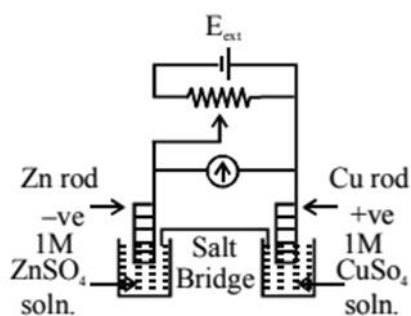

$$E_{\text{Cu}^{2+}/\text{Cu}}^0 = +0.34 \text{ V}$$

$$E_{\text{Zn}^{2+}/\text{Zn}}^0 = -0.76 \text{ V}$$

Identify the incorrect statement from the options below for the above cell

1) If  $E_{\text{ext}} > 1.1 \text{ V}$ , Zn dissolves at Zn electrode and Cu deposits at Cu electrode

2) If  $E_{\text{ext}} = 1.1 \text{ V}$ , no flow of electrons or current occurs

3) If  $E_{\text{ext}} = 1.1 \text{ V}$ , electrons flows from Cu to Zn

4) If  $E_{\text{ext}} < 1.1 \text{ V}$ , Zn dissolves at anode and Cu deposits at s cathode.